

HEADS AND CONES

Shell plates, heads and cones
from a single source

Julia Csarmay, Sales Manager

voestalpine Grobblech GmbH
www.voestalpine.com/grobblech

voestalpine

ONE STEP AHEAD.



MORE THAN JUST SHELL PLATES, HEADS AND CONES FROM A SINGLE SOURCE

Ready for the future

voestalpine Grobblech is the world's only producer of carbon steel, low-alloyed steel and clad plates with integrated production of heads and cones. Heads and cones can be processed of carbon steel, low-alloyed steel or clad plates. We supply shell plates, heads and cones for pressure vessel manufacture from a single source.

CONVINCING ADVANTAGES

- » We offer shell plates, heads and cones from a single source
- » We offer a wide range of products
- » We provide outstanding quality
- » We offer a dedicated R&D expertise





To find out more about heads and cones please visit us at www.voestalpine.com/grobblech

DISCOVER SHELL PLATES, HEADS AND CONES

Typical fields of application

As reliable partner for heads and cones, our typical fields of applications are the refinery, petrochemical and chemical industry, oil and gas production as well as transport industry, energy industry and power plants.

WE DELIVER HEADS AND CONES TO THE FOLLOWING INDUSTRIES

- » Oil and gas industry
- » Refineries
- » Chemical industry
- » Petrochemical industry
- » Transport industry
- » Power plants
- » Energy industry

OUR HEADS AND CONES ARE USED IN

- » Coke drums
- » Reactors
- » Heat exchangers
- » Separators
- » Columns
- » Compressors
- » Storage tanks
- » Special tank wagons
- » Buoyancy tanks



CONVINCING ADVANTAGES

WE OFFER SHELL PLATES, HEADS AND CONES FROM A SINGLE SOURCE

We offer full service, through providing shell plates as well as heads and cones from a single source. By using the same chemical composition of steel grades for plates, heads and cones from the same source, we are creating special advantages during welding.

The technical advice and coordination from one quality and R&D department provides additional benefits.

Furthermore, we help our customer to save time and cost by simultaneous completion and shipment of shell plates, heads and cones.

The resulting decrease of administrative expenses are another great benefit for our customer.

WE OFFER A WIDE RANGE OF PRODUCTS

We are able to provide our customers with a wide range of high-quality products.

- » Hemispherical heads
- » Elliptical heads
- » Torispherical heads
- » Special shapes
- » Flat heads
- » Dished discs
- » Cones
- » Chords
- » Heads for tank wagons
- » Special pressed parts

Due to our dedicated R&D expertise we are able to deliver further special shapes and special pressed parts upon request.

WE PROVIDE OUTSTANDING QUALITY

Our shell plates, heads and cones are made with ultra-clean base materials produced exclusively in our own steel plant in Linz. To achieve outstanding quality we exclusively use materials in best condition without any precipitations.

WE OFFER DEDICATED R&D EXPERTISE

Our Research & Development department is a dedicated center of expertise. As we have an independent and fully accredited testing facility on site we can assure first-class technical investigations.

We calculate the pressing tools for hot forming of heads with the finite element method.





Kempel

3227 14883 32

FORMING PROCESS

The prematerial is rounds cut of heavy plates or roll-bonded clad plates made in-house.

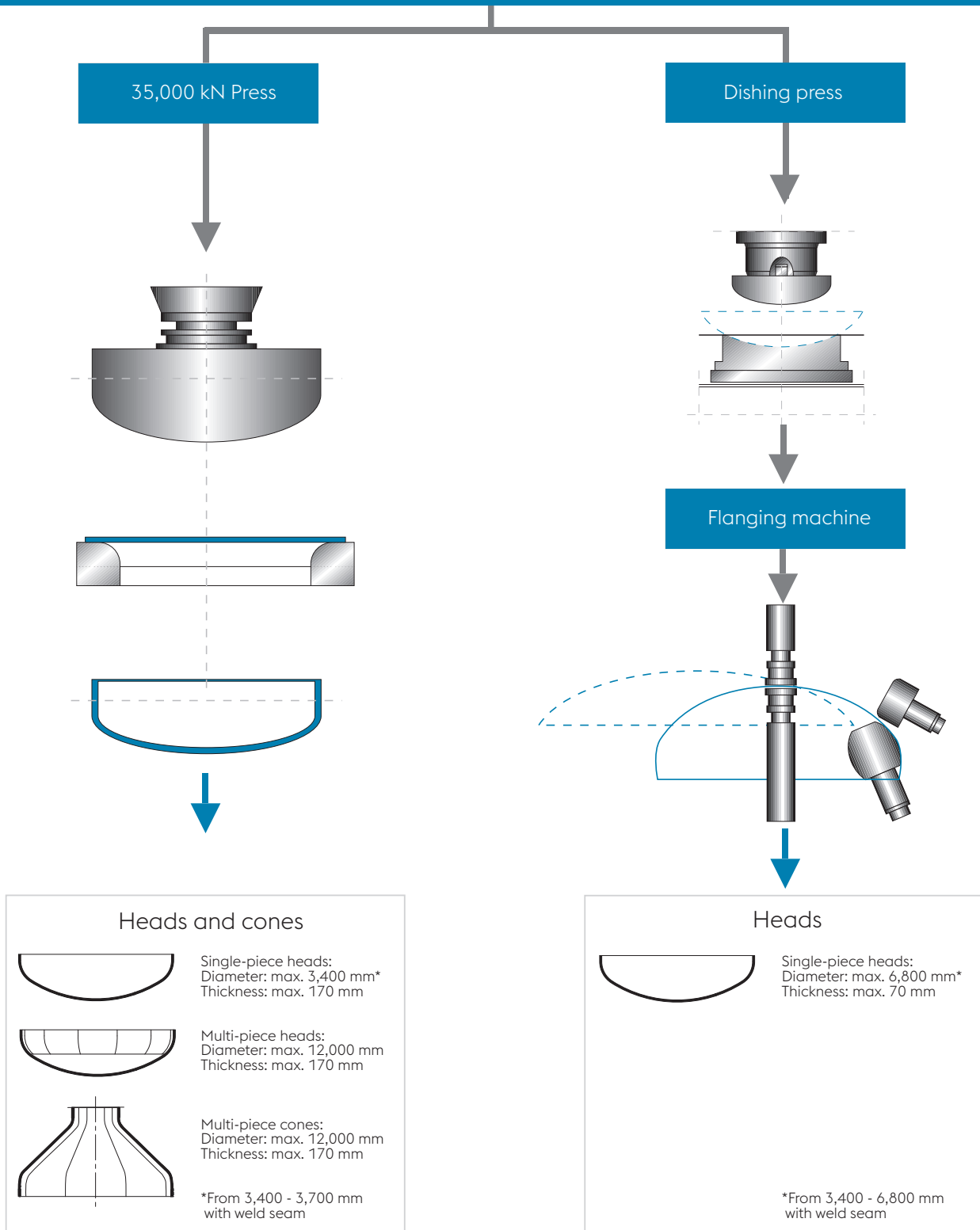

HEMISPHERICAL HEADS

Our hemispherical heads are made of carbon steel or roll-bonded clad plates. We are able to provide a wide range of dimensions. Hemispherical heads which are produced by hot pressing are available as single-piece, single-piece heads with a weld seam and multi-piece heads.

HEMISPHERICAL HEADS WITH STRAIGHT FLANGE

HALBKUGELBÖDEN

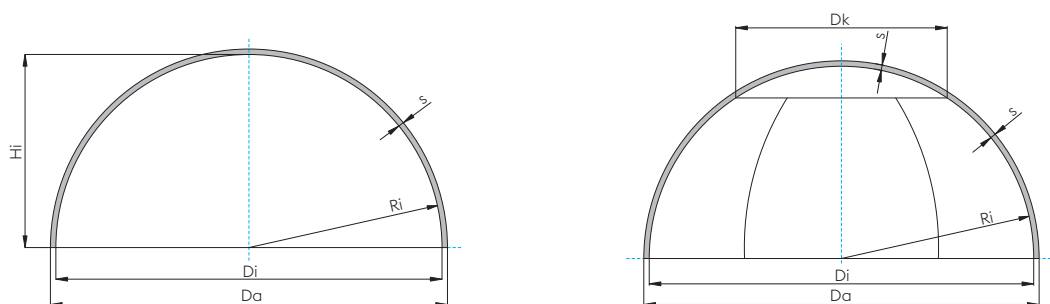

	Outside diameter	Wall thickness
Hot pressed single-piece	800 – 2,800 mm	10 – 170 mm
Hot pressed with weld seam	2,800 – 3,400 mm	10 – 170 mm
Hot pressed multi-piece	3,400 – app. 12,000 mm	10 – 170 mm

Further dimensions upon request.

HEMISPHERICAL HEADS WITH NEGATIVE STRAIGHT FLANGE

HALBKUGELBÖDEN

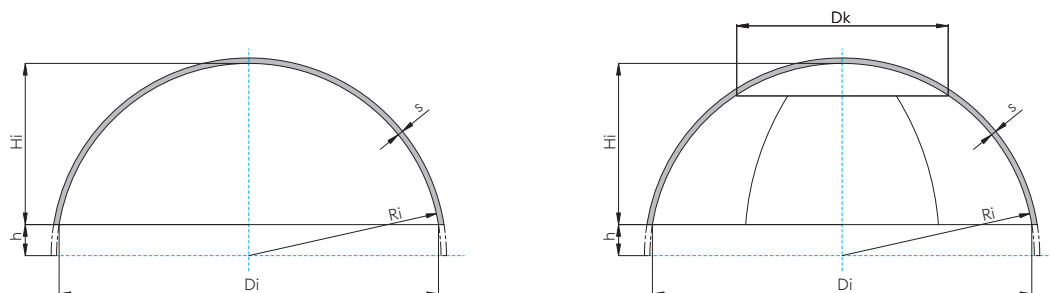

	Outside diameter	Wall thickness
Hot pressed single-piece	800 – 3,000 mm	10 – 170 mm
Hot pressed with weld seam	3,000 – 3,500 mm	10 – 170 mm
Hot pressed multi-piece	3,500 – app. 12,000 mm	10 – 170 mm

Di inside diameter
Da outside diameter
Hi inside height
h straight flange
Ri dish radius
s minimum wall thickness
Dk crown diameter

Further dimensions upon request.

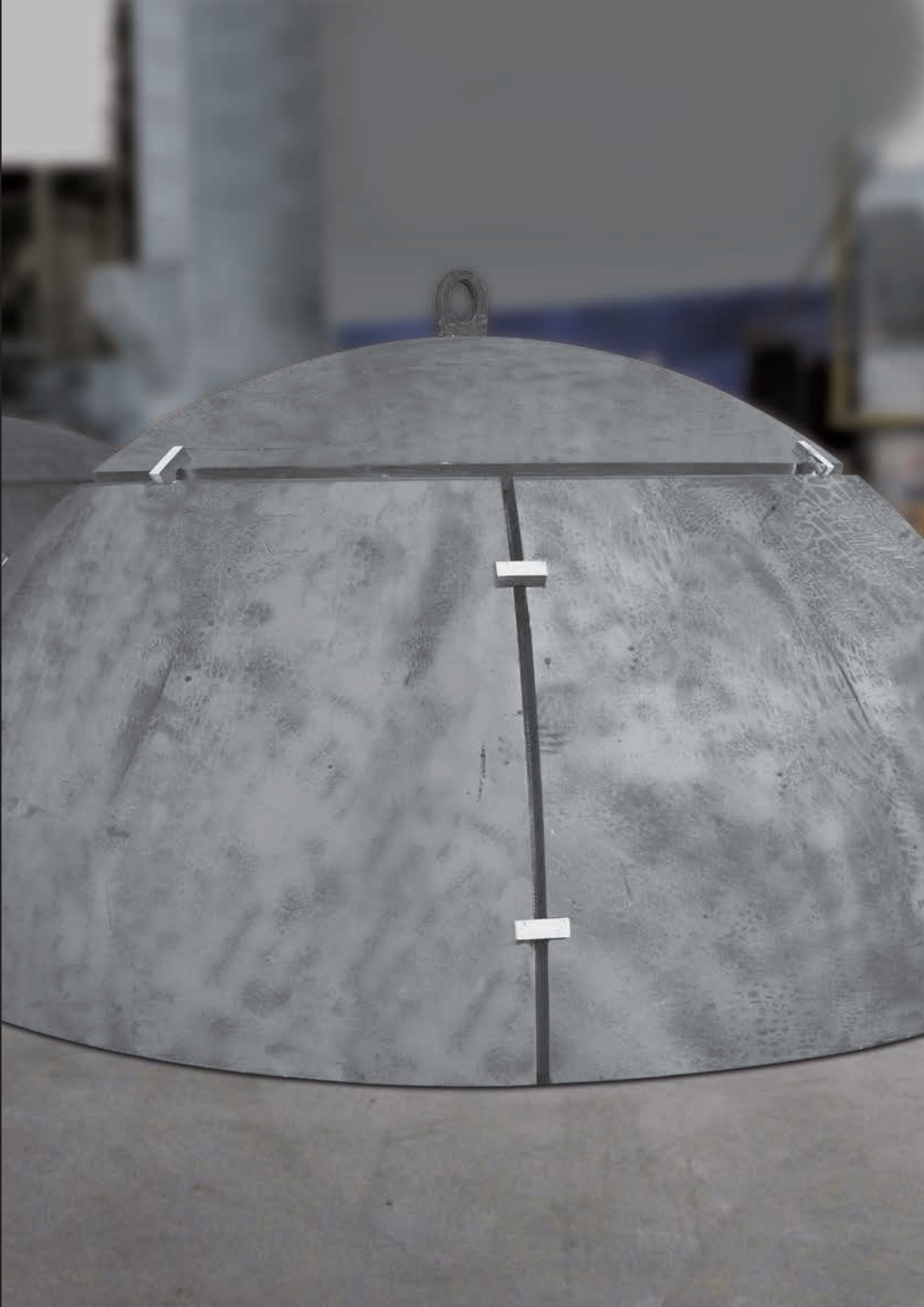

ELLIPTICAL HEADS

We supply elliptical heads made of carbon steel and roll-bonded clad plates. They are available as single-piece, single-piece with a weld seam and multi-piece heads. Single-piece elliptical heads are produced by hot pressing and can be dished and flanged. Multi-piece elliptical heads (crowns and segments) are pressed.

SEMI-ELLIPTICAL HEADS (2:1) ELLIPTICAL HEADS (1.9:1)

KORBBOGENBÖDEN

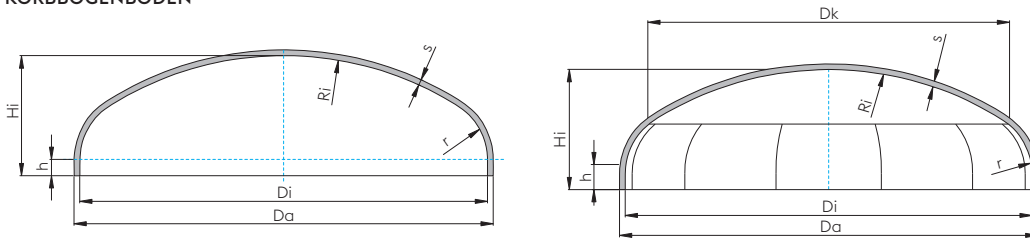

	Outside diameter	Wall thickness
Hot pressed single-piece	800 – 3,000 mm	10 – 170 mm
Cold formed single-piece	2,000 – 3,600 mm	10 – 70 mm
Hot pressed with weld seam	3,400 – 3,800 mm	10 – 170 mm
Cold formed with weld seam	3,400 – 6,500 mm	10 – 70 mm
Hot pressed multi-piece	4,000 – app. 12,000 mm	10 – 170 mm

Di inside diameter
Da outside diameter
Hi inside height
h straight flange
Ri dish radius
r knuckle radius
s minimum wall thickness
Dk crown diameter

Further dimensions upon request.



TORISPHERICAL HEADS

Torispherical heads are made of carbon steel and roll-bonded clad plates. We provide our torispherical heads as single-piece, single-piece with a weld seam and multi-piece heads. Single-piece torispherical heads are produced by hot pressing and can be dished and flanged. Multi-piece heads are produced by hot pressing.

TORISPHERICAL HEADS

KLÖPPERBÖDEN

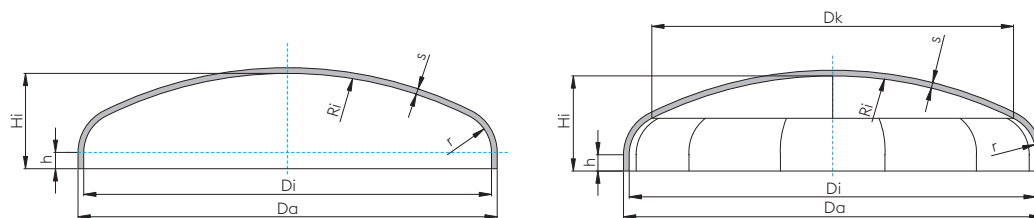

	Outside diameter	Wall thickness
Hot pressed single-piece	800 – 3,400 mm	10 – 170 mm
Cold formed single-piece	2,000 – 3,700 mm	10 – 70 mm
Hot pressed with weld seam	3,400 – 3,800 mm	10 – 170 mm
Cold formed with weld seam	3,400 – 6,800 mm	10 – 70 mm
Hot pressed multi-piece	4,000 – app. 12,000 mm	10 – 170 mm

Di inside diameter
Da outside diameter
Hi inside height
h straight flange
Ri dish radius
r knuckle radius
s minimum wall thickness
Dk crown diameter

Further dimensions upon request.

SPECIAL SHAPES

Special shapes are heads with special shapes with radius outside of the norm which are produced by dishing or flanging. Heads with special shapes are available as single-piece, single-piece with a weld seam and multi-piece heads. Special shapes are also made of carbon steel or roll-bonded clad plates.

FLAT HEADS

Flat heads are only available as single-piece heads. We supply flat heads made of carbon steel and roll-bonded clad plates.

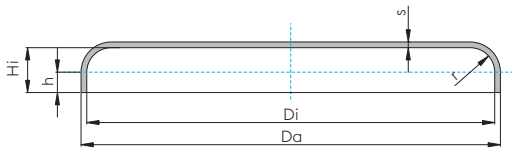

	Outside diameter	Wall thickness
Hot pressed single-piece	800 – 3,800 mm	10 – 170 mm

DISHED DISCS

We supply dished discs made of carbon steel or roll-bonded clad plates. Dished discs are available as multi-piece or single-piece and single-piece with a weld seam. Dished discs are produced by hot pressing or cold forming.

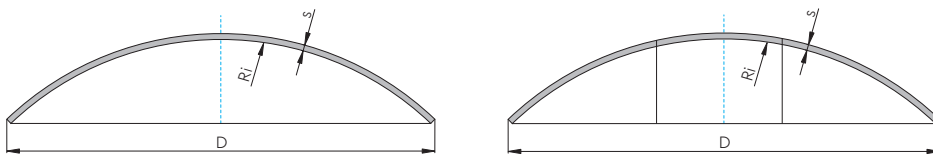

Available in 2 parts, 3 parts or 6 parts with segments and crowns

	Outside diameter	Wall thickness
Hot pressed single-piece	800 – 3,800 mm	10 – 170 mm
Cold formed single-piece	2,000 – 4,000 mm	10 – 70 mm
Hot pressed with weld seam	3,800 – 4,400 mm	10 – 170 mm
Cold formed with weld seam	4,000 – 7,200 mm	10 – 70 mm
Hot pressed multi-piece	3,800 – app. 12,000 mm	10 – 170 mm

Di inside diameter
Da outside diameter
D diameter
Hi inside height
h straight flange
Ri dish radius
r knuckle radius
s minimum wall thickness

Further dimensions upon request.

CONES

Our cones which are made of carbon steel or roll-bonded clad plates are available as multi-piece cones or single-piece cones with a weld seam. Multi-piece cones consist of crowns and segments which are dished and pressed. Matching of all parts is proven by trial assembly. The dimensions of single-piece cones are always dependent on their height.

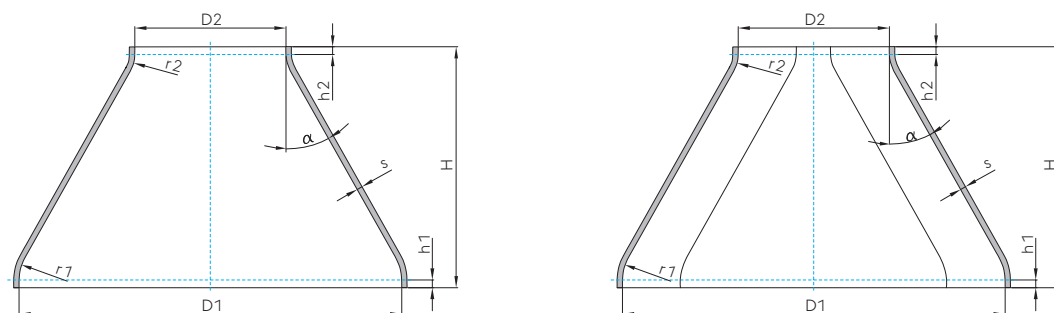

	Outside diameter	Wall thickness
Hot pressed with weld seam	1,400 – 3,800 mm	10 – 170 mm
Cold formed with weld seam	2,000 – 6,500 mm	10 – 70 mm
Hot pressed multi-piece	3,800 – app. 12,000 mm	10 – 170 mm

D1 inside diameter
D2 inside diameter
H height
h1 flange height
h2 flange height
r1 knuckle radius
r2 knuckle radius
s minimum wall thickness
a angle

Further dimensions upon request.



CHORDS

In a specially designed production process, we manufacture high-strength hot-formed components called chords for jack-up rigs. These offshore platforms are supported by adjustable feet. During ocean transport, the feet are retracted and point upwards. At the designated location, the stands are extended until they reach the sea floor. The chords (half shells) made by voestalpine Grobblech strengthen the gear racks of the adjustable feet and allow safe operation in rough conditions.

The high performance of jack-up rigs in a wide range of applications is reliant on first-class leg material. The chords are high-end products as a result of our extensive expertise and ability to control the entire production process coupled with full-service support.

Dimensions		Steel grade		Rules of Classification
Thickness	40 - 120 mm	AB	FQ70	American Bureau of Shipping (ABS)
Length	max. 4,200 mm	NV	F690	DNV-GL
Outside radius	222 - 335 mm			

Further dimensions upon request.

We produce chords for all current rig designs. With our in house tool manufacturing we can support customer's design modifications and supply a tailor-made product.

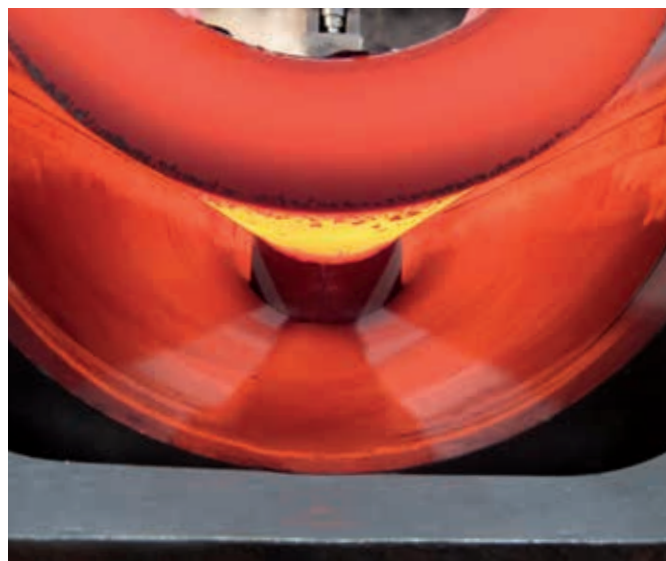
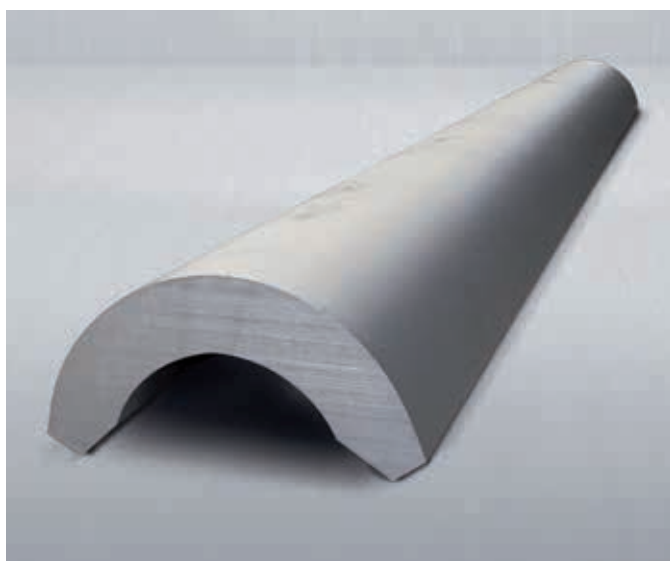

HEADS FOR TANK WAGONS

LPG (Liquified Petroleum Gas) is transported in tank wagons built of **special vessel steels**. In Europe we are the main manufacturer providing both shell plates and heads of special steel grade P460 NL2 mod. (increased tensile strength) according to VdTÜV 531.

PRODUCTS AND DIMENSIONS

Dimensions for plates	
Thickness	7 – 20 mm
Width	1,500 – 3,800 mm ¹⁾
Length	max. 18,000 mm
Weight per plate	max. 18,000 mm

Dimensions for heads	
Thickness	7 – 20 mm
Diameter	1,500 – 3,500 mm ¹⁾

¹⁾ Further dimensions upon request.

MECHANICAL PROPERTIES: TENSILE TEST

Steel grade	Standard	Yield strength $R_{p0.2}$ min. [MPa] $T=20\text{ °C}$	Tensile strength R_m [MPa] $T=20\text{ °C}$
P460 NL2 mod.	VdTÜV 531	460	630 – 725
P400 NGJ2	NFA 36-215	400	550 – 675
P400 NGJ4	NFA 36-215	390	550 – 670
P440 NJ4	NFA 36-215	440	630 – 725
P460 NJ2	NFA 36-215	460	640 – 725



SPECIAL PRESSED PARTS

Not only heads and cones are our specialty but also special pressed parts as alternative to foundry products with the advantage of the high quality through the entire cross section. We produce special pressed parts by hot or cold pressing with special materials like stainless steel (1.4313) or with current materials. Special pressed parts are not only available in solid materials but also as clad materials, in this case cost savings are a great benefit. We are able to produce special pressed parts with a bend of 45°, 60°, or 90° and with or without edge processing. We provide the service of pre-assembling like for the multi-piece heads. We measure the single special pressed parts as well as the complete assembly by very exact laser technology. The scope of application can be water power plants, tidal power plants, pumps or turbines.

Dimensions	
Diameter	≤ 10,000 mm
Thickness	≤ 100 mm
Height	≤ 3,800 mm
Type	multi-piece

Further dimensions upon request.





QUALITY

We produce and deliver our heads and cones as well as our chords out of excellent quality.

Further possible treatments like edge preparation for welding or shotblasting for carbon steel heads complete our high-end products.



HEAT TREATMENT

Heat treatment is set according to material requirements. Water quenching can be provided up to a diameter of 6,500 mm.

- » Normalized (N)
- » Normalized and tempered (N+T)
- » Quenched (Q)
- » Quenched and tempered (Q+T)



EDGE PREPARATION FOR WELDING

Edges are flame-cut in preparation for welding according to customer specifications.

SHOTBLASTING FOR CARBON STEEL HEADS

Carbon steel heads can be shotblasted to a roughness of SA 2.5.



SURFACE FINISH FOR CLAD HEADS

The surface of the base material is normally „as rolled“ or shotblasted. The surface of the clad material depends on the head type:

MULTI-PIECE HEADS

- » Cladding blasted with glass beads for iron-free surface

SINGLE PIECE AND WELDED HEADS

- » Cladding ground with grit 80

Other grit sizes are available on request. The clad surface is protected for transport with a special easily removeable and water-soluble glossy top paint.



TRIAL-ASSEMBLY OF MULTI-PIECE HEADS

All parts of multi-piece heads and cones are trial-assembled to ensure a perfect match.



Our understanding of quality goes far beyond the product. Through continuous development and investment in plant and production technologies we are always one step ahead.

We have a fully integrated steel plant and are able to bundle our expertise for the benefit of our customers. Our different tools in our production site make it possible to supply various types of heads in outstanding quality. This is what sets us apart.

We see our customers as development partners and provide them with excellent planning and advising quality. The exchange of information with our customers as well as the documentation is a great priority for us.

WE ARE CERTIFIED BY

- » Lloyd's Register by ISO 9001
- » „Verband der Technischen Überwachungsvereine“
- » AD Merkblatt W0/TRD 100
- » Pressure Equipment Directive PED 2014/68/EU

STANDARDS

ALL OUR PRODUCTS CAN BE MANUFACTURED IN COMPLIANCE WITH FOLLOWING STANDARDS/CODES

ASME BPVC Section VIII Division 1	American Rules for Construction of pressure vessels (for welded components with ASME PRT Stamp / MPDR form U-2A)
ASME BPVC Section VIII Division 2	American Rules for Construction of pressure vessels – Alternative Rules (for welded components with ASME PRT Stamp / MPDR form A-2)
PED 2014/68/EU	European Pressure Equipment Directive
TPED 2010/35/EU	European Transportable Pressure Equipment Directive
EN 13445	European Standard: Unfired pressure vessels
AD 2000	German codes of practice on pressure vessels
PD 5500	British specification for unfired, fusion welded pressure vessels
CODAP 2010 Division 1 & 2	French Code for Construction of unfired pressure vessels
EN 14025	European Standard: Tanks for the transport of dangerous goods – Metallic pressure tanks – Design and construction
DIN 28011	German Standard: Torispherical heads
DIN 28013	German Standard: Ellipsoidal heads
Other international codes, standards or specifications	ISO 3834-2, NACE, API, ABS, VdTÜV, LR, DNVGL, ADR, RID, IBR, RT0D, SELO, ...

SHAPE CONTROL BY AUTOMATIC LASER MEASUREMENT



TOLERANCES

	Single-piece heads and cones	Multi-piece heads and cones
Diameter ^{1) 2)}	» acc. to applicable standard » voestalpine standard $\pm 0.3\% D$	» acc. to applicable standard » voestalpine standard $\pm 0.2\% D$
Height ¹⁾	» acc. to applicable standard » voestalpine standard $+1.5\% D/-0$, max. 38 mm	» acc. to applicable standard » voestalpine standard $+1.5\% D/-0$, max. 38 mm
Shape	» acc. to applicable standard » special shapes upon request	» radius deviation of crown and segments 3 mm/m from the template
Ovality ¹⁾	» acc. to applicable standard » voestalpine standard $0.5\% D$, max. 30 mm	» acc. to applicable standard » voestalpine standard $0.5\% D$, max. 30 mm
Flatness	» voestalpine standard for flat heads 3 mm/m deviation from measuring rod	
Weld gap	» weld gap ± 2 mm	
Edge	tolerances for edge preparation (flame cut & machined) bevel angle ($\alpha 1, \alpha 2$) $\pm 2^\circ$ depth of preparation (h1) $+2/-0$ mm thickness of root face (c) ± 1 mm thickness after tapering (t) t > 5 – 10 mm $-0/+1$ mm t > 10 – 25 mm $-0/+2$ mm t > 25 mm $-0/+3$ mm taper angle ($\alpha 3$) $\pm 3^\circ$ root radius for U/DU groove ³⁾ ± 1 mm	
	strip back of cladding bevel angle ($\alpha 4$) $\pm 4^\circ$ depth of preparation (h2) $+2/-0$ mm radius (r) ± 1.5 mm depth (x) ⁴⁾ of removal into carbon steel $+1/-0$ mm	

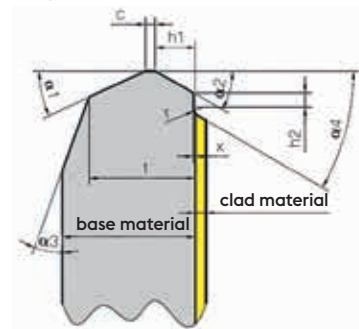

¹⁾ voestalpine standard or other tolerances on request

²⁾ Generally the diameter tolerance is measured on the circumference and calculated as $D = U/\pi$ (D – diameter, U – circumference)

³⁾ Possible up to diameter of 2,200 mm

⁴⁾ Our standard is 0.5 mm

STEEL GRADES

The heavy plates for heads and cones are made of slabs cast at voestalpine steel mill on-site in Linz.

RANGE OF STEEL GRADES

We offer a comprehensive range of steel grades for heads and cones:

- » Structural steels and fine-grain steels
- » Pressure vessel steels

STRUCTURAL STEELS AND PRESSURE VESSEL STEELS ACCORDING TO EN 10025-2, EN 10028-2 AND EN 10028-3

Standard	Steel grade
EN 10025-2	S235JR
	S355JR
EN 10028-2	P235GH
	P265GH
	P295GH
	P355GH
	16Mo3
	20MnMoNi4-5
EN 10028-3	13CrMo4-5
	10CrMo9-10
	12CrMo9-10
	13CrMoV9-10
	P275 NH
	P275 NL1
	P275 NL2
	P355 NH
P355 NL1	
P355 NL2	
P460 NH	
P460 NL1	
P460 NL2	

STRUCTURAL STEELS AND PRESSURE VESSEL STEELS ACCORDING TO ASTM, ASME

Standard	Steel grade
ASME, ASTM	A285 Grade C
	A516 Grade 60
	A516 Grade 65
	A516 Grade 70
	A572 Grade 65 Type 1
	A 204 Type A
	A 204 Type B
	A 302 Type B
	A 533 Type B Class 1
	A533 Type B Class 2
	A387 Grade 11 Class 2
	A387 Grade 12 Class 2
	A387 Grade 22 Class 2
A 542 Type D Class 4	

These are the base materials – further materials upon request.

CLADDINGS

Clad heads and cones are made of roll-bonded clad plates made by voestalpine Grobblech.

Below you will find a summary of the most frequently used clad materials for heads and cones. Other clad materials on request.

STAINLESS STEELS AND HEAT-RESISTANT STEELS

Standard	EN material number	Steel grade	
EN 10088	1.4000	X6Cr13	
	1.4301	X5CrNi18-10	
	1.4306	X2CrNi19-11	
	1.4541	X6CrNiTi18-10	
	1.4550	X6CrNiNb18-10	
	1.4401	X5CrNiMo17-12-2	
	1.4404	X2CrNiMo17-12-2	
	1.4571	X6CrNiMoTi17-12-2	
	1.4432	X2CrNiMo18-14-3	
	1.4435	X3CrNiMo17-13-3	
	1.4429	X2CrNiMoN17-13-3	
	1.4438	X2CrNiMo18-15-4	
	1.4439	X2CrNiMoN17-13-5	
	SEW 470	1.4828	X 15 CrNiSi 20 12

Standard	UNS number	Steel grade
ASTM A240 and ASME SA240	S41008	410S
	S30400	304
	S30403	304L
	S32100	321
	S34700	347
	S31600	316
	S31603	316L
		316L Mod Mo \geq 2.5
	S31635	316Ti
	S31653	316LN
	-	316LN Mod Mo \geq 2.5
	S31703	317L
	S31726	317LMN

CLADDINGS

We mainly use

- » Ferritic and austenitic stainless steels and heat-resistant steels
- » Nickel and nickel-based alloys
- » Copper and copper-alloys

SPECIAL STEELS, NON-FERROUS METALS AND ALLOYS

ASTM	Type
B 409 UNS N08800	Alloy 800
A 240/A 240M UNS N08904	Alloy 904 L
B 709 UNS N08028	Alloy 28
B 677 UNS N08926	Alloy 926
B 463 UNS N08020	Alloy 20
B 463 UNS N08020	Alloy 20
B 424 UNS N08825	Alloy 825
B 443 UNS N06625	Alloy 625
B 575 UNS N06022	Alloy C 22
B 575 UNS N06455	Alloy C 4
B 575 UNS N10276	Alloy C 276
B 575 UNS N06059	Alloy 59
B 333 UNS N10665	Alloy B 2
B 168 UNS N06600	Alloy 600
B 127 UNS N04400	Alloy 400
B 162 UNS N02200	Alloy 200
B 162 UNS N02201	Alloy 201
B 152 UNS C12200	-
B 171 UNS C70600	Alloy CuNi 90/10
B 171 UNS C71500	Alloy CuNi 70/30

BASE MATERIALS

We offer the same steel grades as for heads and cones of carbon steels (see page 26). Alternative base materials on request.

WE TALK SOLUTIONS

That is why we will never be satisfied with excellent product quality alone.

Comprehensive services and unlimited dedication to the challenges of our customers are at the core of our philosophy.

Highly specialized and closely linked, the companies of the voestalpine Steel Division have one common goal, which is providing our customers with optimized and individualized packages of benefits.

PROGRESS THROUGH R&D

- » Continual product and process development
- » Innovative solutions for products and processes
- » Independent and fully accredited testing facility on-site
- » Simulations of material performance of weldability, deformation and edging behavior, fatigue tests and fracture mechanics
- » Consultation in the fields of welding and processing

A UNIQUE LOGISTICS PACKAGE

- » Partnerships with our clients and customers
- » Reliable and flexible delivery performance
- » Professional project management ensuring successful delivery of complex orders
- » Dedicated mill-based project management team for order management from pre-production to post-production to support
- » Complete project documentation package (inspection and testing plan, manufacturing specifications, ultrasonic testing procedures)
- » Prompt reaction to inquiries
- » Web-based customer service center with customer access to order confirmations, invoices, test certificates and order status

A STRONG PARTNERSHIP

- » Close collaboration with our Group companies in order to obtain unique expertise and ensure the technological leadership of our products
- » You can find more voestalpine product information at voestalpine Böhler Welding (www.voestalpine.com/welding/group)

WE LEAD THE WAY, SO OUR PARTNERS WILL BE ONE STEP AHEAD.

Many years of partnerships with renowned companies impressively prove our point.



BOSCH



BILFINGER

Bilfinger Industrial
Services GmbH



WAGGONBAU GRAAFF

Member of the VTG Group



LARSEN & TOUBRO



IDESA
ingeniería y diseño europeo, s.a.

VOITH



Hiperbaric
HIGH PRESSURE PROCESSING

GREENBRIER
EUROPE

The information and product properties contained in this printed material are non-binding and serve the sole purpose of technical orientation. They do not replace individual advisory services provided by our sales and customer service teams. The product information and characteristics set forth herein shall not be considered as guaranteed properties unless explicitly stipulated in a separate contractual agreement. For this reason, voestalpine shall not grant any warranty nor be held liable for properties and/or specifications other than those subject to explicit agreement. This also applies to the suitability and applicability of products for certain applications as well as to the further processing of materials into final products. All application risks and suitability risks shall be borne by the customer. The General Terms of Sale for Goods and Services of the voestalpine Steel Division shall apply to all materials supplied by the voestalpine Steel Division and can be accessed using the following link: www.voestalpine.com/stahl/en/The-Steel-Division/General-Terms-of-Sale

Technical changes are reserved. Errors and misprints are excepted. No part of this publication may be reprinted without explicit written permission by voestalpine Stahl GmbH.

04/2021

voestalpine Grobblech GmbH
voestalpine-Straße 3
4020 Linz, Austria
T. +43/50304/15-9440
F. +43/50304/55-9440
grobblech@voestalpine.com
www.voestalpine.com/grobblech

voestalpine

ONE STEP AHEAD.